

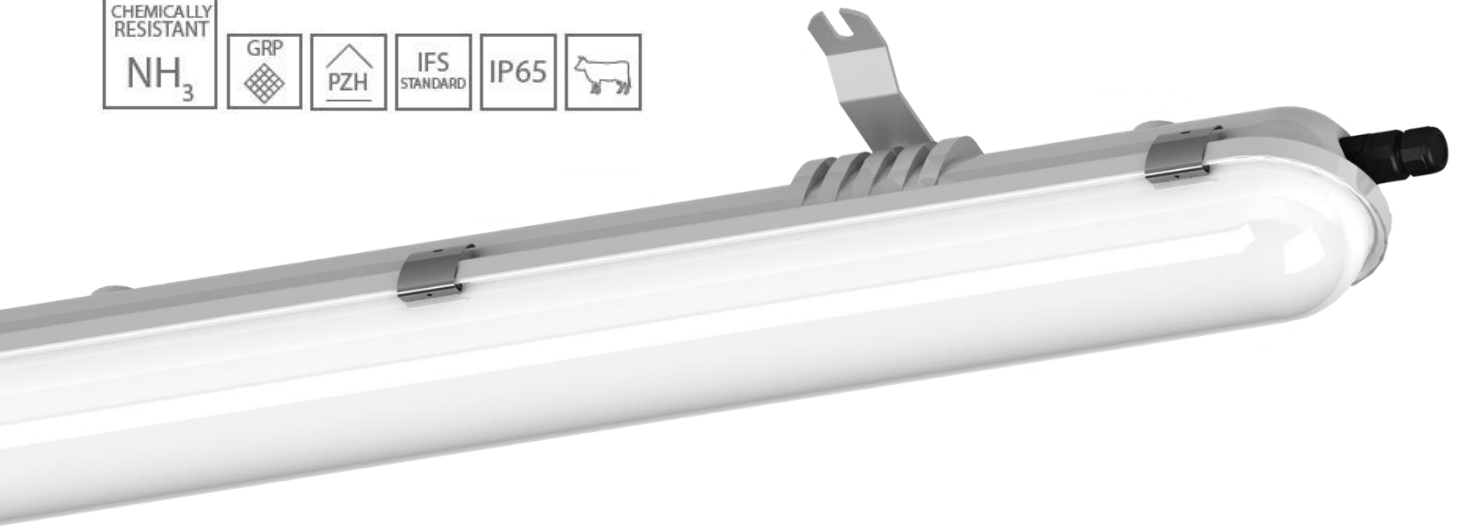

INSTALLATION AND MAINTENANCE MANUAL FOR
LIGHT FITTING

INS270LED



Carefully read the instructions before
mounting the light fitting.

TABLE OF CONTENTS

1.	GENERAL INFORMATION.....	3
2.	TECHNICAL INFORMATION.....	3
3.	PHOTOMETRICAL DATA.....	4
4.	CONSTRUCTION DESCRPTION	4
5.	PRELIMINARIES.....	4
6.	LIGHT FITTING MOUNTING.....	4
7.	ELECTRICAL CONNECTION	5
8.	CONDITIONS OF SAFETY USE.....	5
9.	LIGHT FITTING MAINTANANCE AND SERVICING	5
10.	PARTS EXCHANGE	6
11.	REPAIRING	6
12.	LAMPS EXCHANGE	6
13.	TRANSPORT AND CONDITIONS OF STORAGE	6
14.	DISPOSAL OF WASTE EQUIPMENT	7
15.	WARRANTY	7

1. GENERAL INFORMATION

Industrial light fitting with LED modules. Specially selected materials are chemically aggressive environment (e.g. ammonia) resistant. This allows to use the device in food industry and animal husbandry.

I	N	S	2	7	0	L	E	D	-	1	2	0	0	-	J	2	-	1	-	3	5	E	-	3	0	-	1	0	-	P	2	0	-	GR	P	M	M	A	-	A	M	O	1
grupa	typ	przybliżona długość	typ modułu LED / LED module type	ilość /quantity	prąd sterowania	zasilanie	okablowanie	wpusty kablowe	materiał obudowy	materiał klosza	uchwyt mocujący																																
group	type	approximate length	type of LED module / LED module type	quantity	driving current	power supply	wiring	inlets	housing material	diffuser material	outlet bracket																																
													33	1 1	2 5																												
													AMO2	AMO3	AMO4	AMO5	AMO10																										

2. TECHNICAL INFORMATION

Type	Power	Electrical unit	IP	Protection class	Power factor	Ambient temp.
INS270LED-1200-J2-1	20,5 W	230V	65	I	≥0,95	-25 to +45 °C
INS270LED-1200-J2-3	29,5 W	0,50,60Hz				-25 to +40 °C

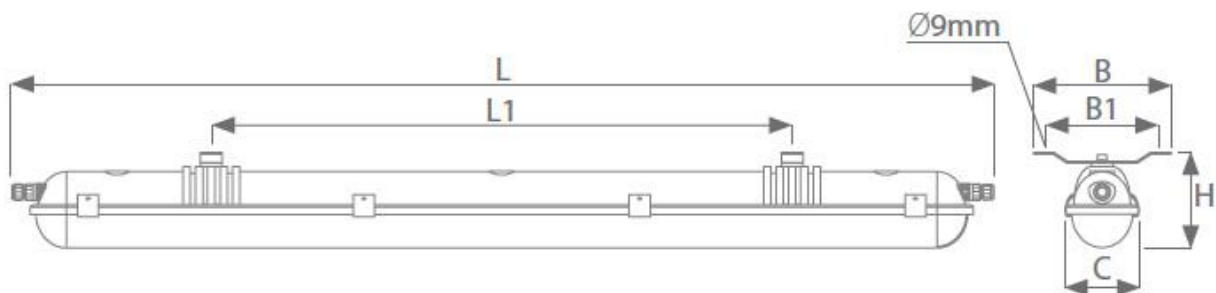

Typ oprawy	L	L1	C	B	B1	H
INS270LED-1200	1353	800	100	190	160	132

3. PHOTOMETRICAL DATA

Type	Luminous flux	Efficiency	Colour temperature	CRI	Lifetime
INS270LED-1200-J2-1	2346 lm	114 lm/W	4000K	>80	>70000 h
INS270LED-1200-J2-3	3128 lm	106 lm/W			

Lifetime of a LED modules: L₈₀B₁₀

4. CONSTRUCTION DESCRIPTION

Housing is made of glass fibre reinforced polyester. Diffuser is made of polycarbonate PMMA. Mounting tray is made of galvanized steel sheet. Clamps are made of stainless steel.

5. PRELIMINARIES

CONDITIONS OF SAFETY RULES

- Carefully read all the information included in the manual before mounting the light fitting
- General safety must be applied.
- Failure to comply with rules of the installation and use can lead to personal injury or property losses. Company ATM Lighting sp. z o.o. takes no responsibility in such cases.
- Failure to comply with rules included in manual results with void of the manufacturer warranty.

NECESSARY TOOLS

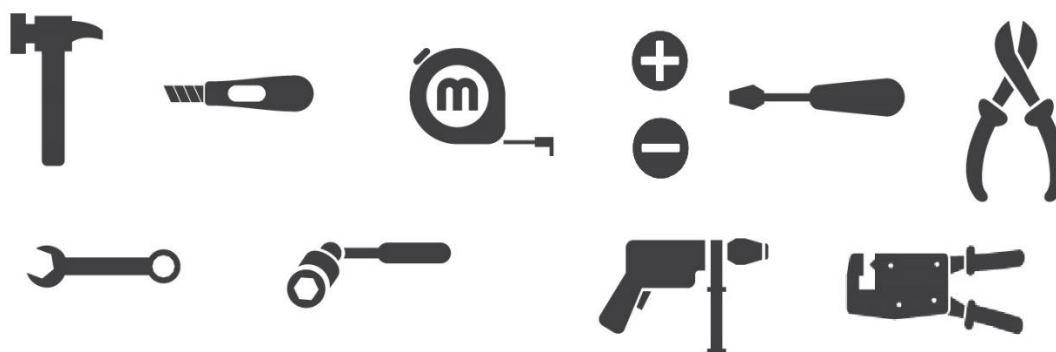

6. LIGHT FITTING MOUNTING

Light fitting is designed for direct installation on ceiling, wall or suspending.

7. ELECTRICAL CONNECTION

To connect power supply:

- enter the power cable to the housing through the cable entry (gland),
- carefully unisolate the cables cores (8-10mm), and put it into the connector according to marking inside the light fitting,
- precisely tighten power cable in the gland with two wrench,
- check the effectiveness of grounding.

Power connection:

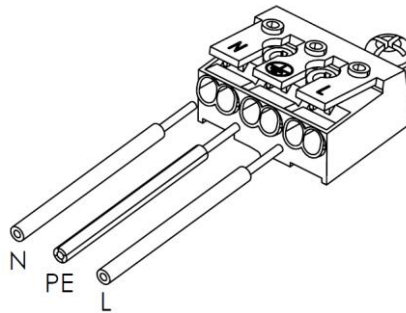

Remarks:

- Use one wrench to tighten the sealing nut, while using the second wrench to block gland body against rotation, otherwise damage of the sealing can be caused and therefore sealing level will be decreased.

8. CONDITIONS OF SAFETY USE

- Every light fitting has to have rating plates with rating data on it. Each light fitting must have this „Installation and maintenance manual” , which must be kept by user until the end of exploitation.
- Light fittings are designed for fixed installations only.
- Using light fitting outside the designated operating temperature range will decrease a lifetime of light fitting and/or damage it. It will also cause a loss of warranty.
- Each light fitting must have a warning sign: „do not open under voltage” on it.
- Admission cables must have 3-wires (with PE wire) and diameter 8-13mm.
- Use power wires with cross section 0,5-1,8mm².
- Maximum cross current I=16A.

9. LIGHT FITTING MAINTENANCE AND SERVICING

REMARK: during the servicing and maintenance touching of LED are prohibited, because it will decrease the lifetime of light fitting and cause the loss of manufacturer’s warranty.

INSPECTION: at least once a month. Inspection is made without opening the light fitting. User must check admission cables condition (insulation damage, cracks, burns etc.). Cables must not have any acute bends. Outside parts of the light fitting must be checked. No cracks or corrosion signs may occur. Bolts used to mount light fitting should be properly tightened, washers mustn't be cracked. Cleanliness of outer surfaces and light fittings surroundings must be checked. Light fittings may not be soiled by paint or grease. Do not allow for dust (dirt) deposition on the light fitting. The readability of rating and warning plates must be checked. Abnormalities found must be fixed.

SERVICE AND MAINTENANCE: at least once a year. Service and maintenance must be made with power supply turned off. User must make inspection steps first. After opening the metal parts painting, condition of inner wiring and its mounting, insulating materials, cable glands gaskets, terminals. Abnormalities found must be fixed. Rating and warning plates must be cleaned. Surfaces of insulating materials and covers must be clean.

VERIFICATION OF TECHNICAL CONDITION: at least once for 2 years. Power supply must be switched off. Light fitting must be uninstalled. Besides all the examination from inspection, service and maintenance paragraphs electrical examination from the inspection, service and maintenance paragraphs electrical examination must be also made: light fitting current consumption, insulation examination, protective earthing condition. Special attention must be paid to insulating parts condition. No crack or burns may occur.

CLEANING: do not allow for dust (dirt) deposition on the light fitting. Cleaning must be proceeded without use of chemical. Cleaning must be proceeded with use of compressed air and soft cleaning cloth or soft brush. If necessary use water and/or neutral detergent, however without any chemicals, which can damage any part of the light fitting.

10. PARTS EXCHANGE

All of parts considered as a spare parts must be ordered at manufacturer of light fitting.

11. REPAIRING

All repairs (excluding lamps exchange) may be made only by manufacturer or authorized repair workshops.

12. LAMPS EXCHANGE

Can be performed only by personnel appropriately trained and authorized to the service of the light fitting.

13. TRANSPORT AND CONDITIONS OF STORAGE

During transportation light fittings shouldn't be exposed to precipitation or mechanical shock.

Light fittings may be storage only in sheltered warehouses, within +5°C to +35°C temperature range, and relative humidity lower than 75%. No corrosion causing vapors or gases should be present.

14. DISPOSAL OF WASTE EQUIPMENT

User must obey relevant rules and regulations about disposal of wasted equipment valid in their country.

15. WARRANTY

- It is forbidden to use damaged or malfunctioned light fitting.
- It is required to disconnect power supply from the light fitting before any maintenance work.
- All specific information can be found in document „General terms and conditions warranty ATM Lighting sp. z o.o.” available at the website www.atmlighting.pl/en/

ADDRESS:

ATM Lighting sp. z o.o.

ul. Budowlanych 31 80-298 Gdańsk

tel: +48 58 347 51 07 fax: +48 58 347 51 08

[office\[at\]atmlighting.pl](mailto:office[at]atmlighting.pl)